

User Manual

Shower Stretcher Fixed Height

CONTENTS

Contents

1.0	Safety Instructions and Warnings.....	4
1.1	Introduction	4
1.2	Service and Support	4
1.3	Symbols Used.....	5
1.4	Contraindications/Limitations	5
1.5	Intended Use	6
1.5.1	Intended User.....	6
1.6	Shower Stretcher Operating Environment	6
1.6.1	Frequency of use:.....	6
1.7	Shower Stretcher Essential Performance	6
1.8	Vicinity to Other Equipment	7
1.9	Incident Reporting.....	7
1.10	Additional Warnings and Safety Notices.....	7
2.0	Components/Key Parts	8
2.1	Key Parts	8
2.2	Packaging.....	8
3.0	Installation.....	9
3.1	Surveying Procedure	9
3.2	Installation Tools Required	9
3.3	Installation Procedure	9
3.4	Adjustments	13
3.4.1	General Use	13
3.4.2	Head Rest	14
4.0	Compatible accessories	15
4.1	Safety Rail	15
4.2	Drip Tray.....	16
4.2.1	Technical Data	16
4.2.2	Tools Required.....	16
4.2.3	Parts Required	17
4.2.4	Installation.....	18
4.2.5	Attaching The Hose.....	21
4.2.6	Using The Drip Tray	21
4.2.7	Adjustments.....	23
5.0	Technical Specification	25
5.1	Shower Stretcher Dimensions	25
5.2	Environmental - Storage and Operating Conditions.....	26
5.2.1	Normal operating conditions.....	26

CONTENTS

5.2.2	Shipping and storage conditions	26
5.3	Standards Applied.....	27
5.4	Disposal	27
6.0	General Inspection and Maintenance.....	28
6.1	Daily Checks - To Be Completed by User.....	28
6.2	Service Interval	28
6.3	Nominal Service Life	28
6.4	Extending Nominal Service Life	29
6.5	User Serviceable Parts	29
6.6	Final Inspection.....	29
7.0	Cleaning	30
7.1	General cleaning.....	30
8.0	Service Documentation	31
8.1	Documentation/ Records	31
8.2	Service Record History	32
8.2.1	Product Information	32
8.2.2	Service & inspection record form:.....	32
9.0	Warranty	33
10.0	Continuous improvement.....	33

1.0 SAFETY INSTRUCTIONS AND WARNINGS

1.1 Introduction

The information in this manual is important to your safety.



Please read and understand this manual in its entirety before using your Easi Shower Fixed.

**If you require larger print or videos – these are available on the Smirthwaite website:
www.smirthwaite.co.uk/product/Shower-Stretcher-Fixed/**

The information in this manual is important for the safety of anyone near the Easi Shower Fixed and must be read and understood to help prevent injuries. It is also crucial to the proper operation and maintenance of the Easi Shower Fixed.

Store this manual with the documents included with the Shower Stretcher. The Easi Shower Fixed is designed to be used in conjunction with approved accessories. Please refer to any user guides supplied with these components while reviewing this manual.

Contents of this manual are subject to change without prior notice.



Unauthorised modifications on any Smirthwaite product may affect its safety. The manufacturer will not be held responsible for any accident, incident or deficiencies of performance that occur as a result of any unauthorised modification to its products.

1.2 Service and Support

To ensure the safety and continued good function of your product, routine service must be performed on your Easi Shower Fixed.

For further details, see section 6.0 General Inspection and Maintenance.

As well as inspections and simple checks completed by the user, every 1 year a service must be completed by Smirthwaite Ltd authorised trained service staff.

















Contact your local authorised Smirthwaite dealer if you:

- Need more information.
- Have any questions about the use or maintenance of your Easi Shower Fixed.
- Notice any change in the performance of your Shower Stretcher.
- Want to report an unexpected occurrence.
- Want to arrange a service.

Contact details of your local Smirthwaite dealer are shown on the last page of this manual.

SAFETY INSTRUCTIONS AND WARNINGS

1.3 Symbols Used

	Consult instructions before use		Caution
	Class II Equipment - electrical equipment in which protection against electric shock does not rely on basic insulation only	SWL	Safe Working Load represents the maximum load rated for safe operation
	Manufacturer		Date of manufacture
	Packaging indicator – This way up		Packaging indicator – Keep dry
	Serial number		For internal use only
	Please observe local laws on recycling	IP_{N₁}N₂	Degree of protection provided by enclosure. N ₁ : Ingress of particles N ₂ : Ingress of water
	Temperature range		Humidity range
	Type 'B' applied part		Type 'BF' applied part
	Medical Device		Authorised representative in the European Community

1.4 Contraindications/Limitations

There are no known “contraindications” associated with the usage of the Easi Shower Fixed and its accessories, provided they are used as per manufacturer’s recommendations and guidelines.

Smirthwaite Ltd. does not recommend a required number of care givers for the use of our products. This information and recommendation can only be provided after a thorough

SAFETY INSTRUCTIONS AND WARNINGS

personalised, case specific assessment, as there are many factors that can influence these decisions.

1.5 Intended Use



For internal use only.

Intended to support a recumbent patient for changing purposes

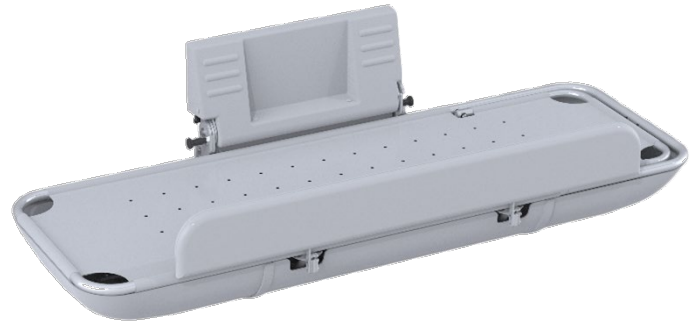

1.5.1 Intended User

The Easi Shower Fixed has been designed for use by a child's carer, therapist, and/or teaching staff who will maintain and clean the Shower Stretcher as per the recommended guidelines in section 7.0 Cleaning.

The Easi Shower Fixed is designed to be checked and adjusted by a therapist to ensure the child is positioned correctly.

1.6 Shower Stretcher Operating Environment

The Easi Shower Fixed is suitable for use within the professional health care facility environment as well as the home health care environment.

The Shower Stretcher is not intended to be used in environments where there are rapid changes in the environmental temperature and humidity during intended use.

The Easi Shower Fixed is intended for indoor use only; the normal operating conditions are as follows:

- A. Temperature: 41°F to 86°F (+5°C to 40°C)
- B. Relative Humidity: 15 to 90%, non-condensing, but not requiring a water vapour pressure greater than 50hPa.
- C. Atmospheric Pressure: 700hPa to 1060hPa.
- D. Ambient luminance 50 – 500 lux.
- E. Viewing distance: 0 metre to 1.5 metre

1.6.1 Frequency of use:

The Easi Shower Fixed can be used without any frequency restrictions.

1.7 Shower Stretcher Essential Performance

The essential performance of the Shower Stretcher is defined as:

The shower stretcher and changing bench fixed height is designed to allow the washing or showering of the user whilst in a horizontal position.

1.8 Vicinity to Other Equipment

Use of this equipment stacked with other equipment should be avoided, unless the equipment is an approved accessory.

Contact your local authorised dealer if assistance is required – contact details on the last page of this manual.

1.9 Incident Reporting

If, during the use of this device or as a result of its use a serious incident has occurred, please report it to the manufacturer and the competent authority of the member state in which the user and/or patient is established.

1.10 Additional Warnings and Safety Notices

- The patient should NOT be left unattended whilst in the product. Always ensure a responsible therapist or carer is in attendance.
- The carer should be familiar with the methods of use before transfer of a patient onto the product.
- If fitted, ensure the safety guard rail is in the 'up' position once a patient is on the shower stretcher.
- When storing the product vertically (up position), check to ensure that the locking plunger pin is fully engaged.
- Regular maintenance checks and cleaning are essential for the safe use of this equipment (see care and maintenance section).
- Always keep this product away from naked flames, cigarettes and sources of heat including open fireplaces, radiators and heaters.
- DO NOT fit parts or accessories of other manufacturers to this product unless authorized to do so in writing by Smirthwaite Ltd. Failure to follow these instructions will not only invalidate the guarantee but could make the product dangerous to use. Smirthwaite Ltd will not accept liability for any injury or damage incurred through such malpractices.
- In the unlikely event repair work is required it must ONLY be undertaken by Smirthwaite authorized personnel.
- If you believe the product or any fitted accessory to be faulty at any time, DO NOT USE – contact Smirthwaite by telephone on +44 (0) 1626 835552.
- This product is CE marked. This certifies that it meets all relevant/applicable European directives.

2.0 COMPONENTS/KEY PARTS

2.1 Key Parts

When delivered, the Shower Stretcher will be supplied fully assembled. Always turn hand wheels, levers and screws clockwise to tighten or anti-clockwise to loosen. Conveniently packaged in a single box, the following components are included with your new Easi Shower Fixed:

Item	Description
A	Durable Non-Rip Vinyl
B	Shower Stretcher Frame
C	Wall Frame Cover
D	Enclosed Dampener Strut
E	Safety Guard Rail (Optional)
F	Drip Tray (Optional)

Table 1

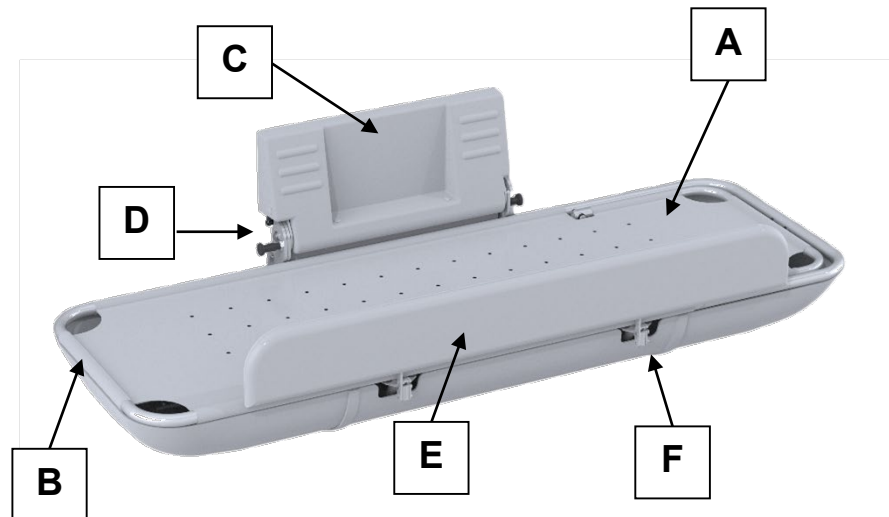

2.2 Packaging

- When delivered, the Shower Stretcher will be supplied fully assembled.
- If your order has been supplied as a custom kit, please ensure you follow both the instructions documented in this User Manual **and** any additional instructions supplied.
- Please take note of any instructions on the packaging/box when unpacking.
- Once the Shower Stretcher has been carefully unpacked, please check all parts.

3.0 INSTALLATION

When delivered, the Shower Stretcher will be supplied fully assembled. Always turn hand wheels, levers and screws clockwise to tighten or anti-clockwise to loosen.

3.1 Surveying Procedure

- Shower stretchers are often installed in small rooms with limited space. In such circumstances it is vitally important to take accurate measurements of the whole room in question, and make a plan to scale if possible.
- Ensure that the intended wall for installation is strong enough to support the weight of the stretcher plus the patient.
- If the wall is of brick or concrete construction it will be strong enough to support the equipment without need of the backing board.
- If the wall is of hollow or soft insulation block construction, then we would always recommend the backing board is used.
- Check for the position of dado rails, window sills, electrical power points, switches, etc. which may adversely affect the installation.
- Check there is sufficient room around other facilities, e.g. wash basins, toilets, etc.
- Remember to take into account the guard rail dimensions (accessory).
- Check that access to doorways is still possible.
- Inspect the wall to see if padding/spacing is required to correct wall imperfections.

3.2 Installation Tools Required

- Electric hand drill, with appropriate drill bits for wood and masonry
- Set of spanners
- Tape measure
- Spirit level
- Hammer
- Screw driver
- Personal Protection Equipment (PPE); gloves, safety glasses

3.3 Installation Procedure

- Carefully unpack the shower stretcher and lay all parts on to the floor.
- Check all component packs are present
- Check all components for damage that may have occurred during transit (see illustration below):

INSTALLATION

Wall Bracket Assembly

Qty: 1

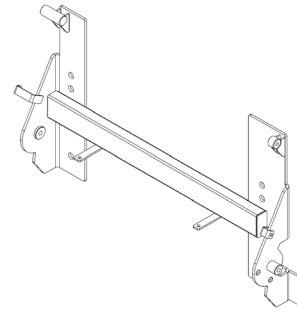

Wall Bracket Cover

Qty: 1

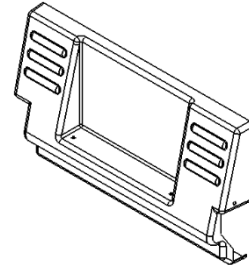

Stretcher Frame^{1,2}

Qty: 1

- 1. Frame will vary dependent upon length chosen
- 2. Frame will vary if headrest accessory is chosen

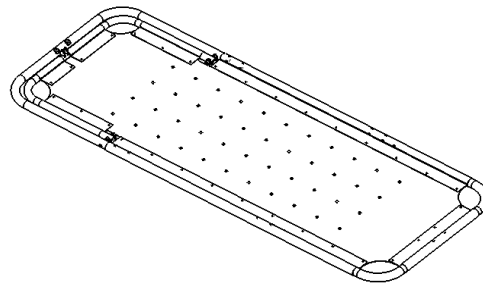

Safety Guard Rail³

3. Accessory item

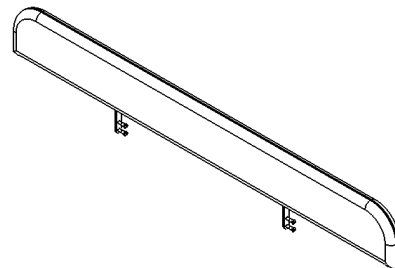

Fixing Kit⁴

Qty: 1

4. Exact contents may vary from illustration

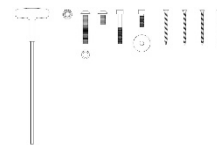

It is strongly recommended that two people carry out the installation due to the weight of the product.

INSTALLATION

- Store the stretcher frame, back cover and backing board (if ordered) somewhere safe.
- Position the wall bracket assembly level on the desired wall at an appropriate height, ensuring you have checked for clearances as described before.
- The bench can be positioned above a bath to aid water collection, or simply fastened to a wall in a suitable wet room.
- Mark and drill the holes for the fixings.

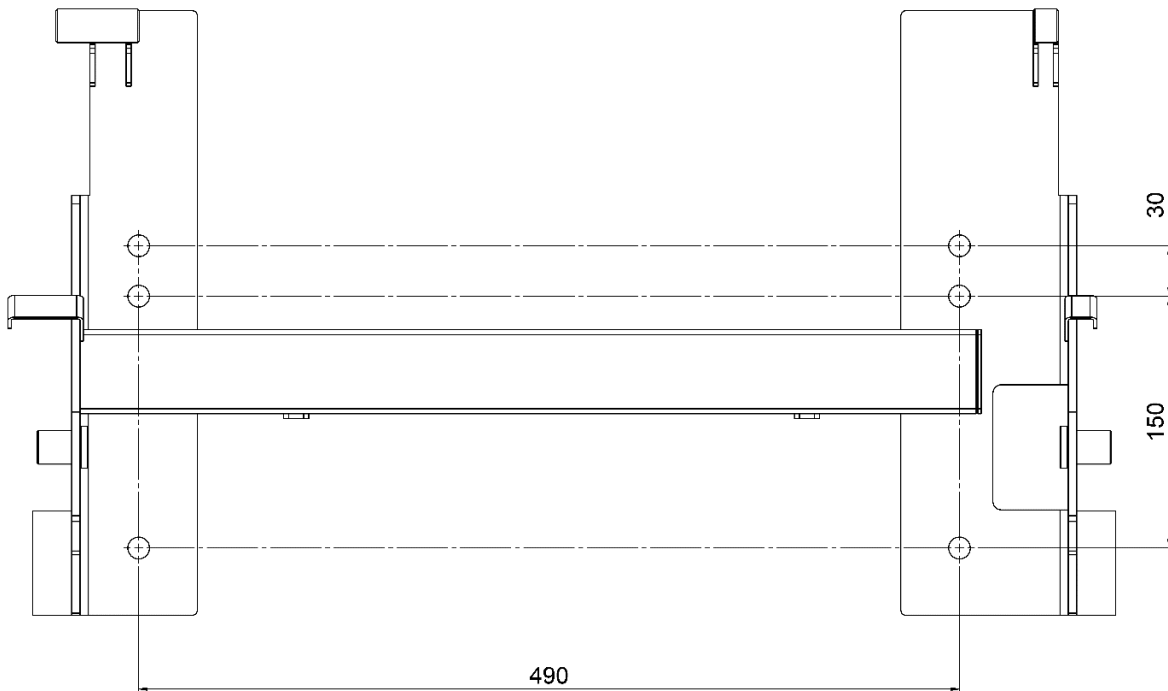

- Where a backing board is to be used, it should be drilled to take a minimum of 8 fixing screws – check screws do not interfere with the wall bracket assembly once mounted.
- Fix the frame assembly to the wall, checking the wall bracket assembly is level and vertical before tightening the fixings – use packing if required.
- Offer up the stretcher frame to the wall bracket assembly, fixing into place using 3 screws per side as shown below (M10 x 20mm screws, total quantity 6)
- Ensure the screw fixings are tight

INSTALLATION

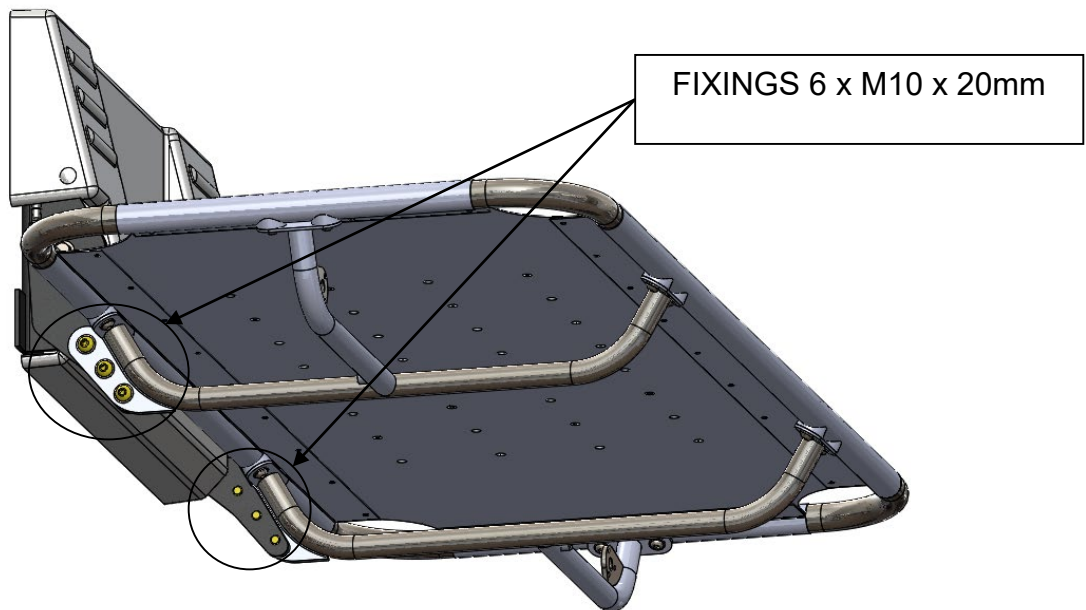

- Check that the stretcher frame can be rotated from horizontal to vertical without obstruction.
- Check that the stretcher frame can be stored securely vertically using the plunger locking pin (circled below). To return the stretcher to horizontal, pull the plunger locking pin, and rotate the stretcher downwards.

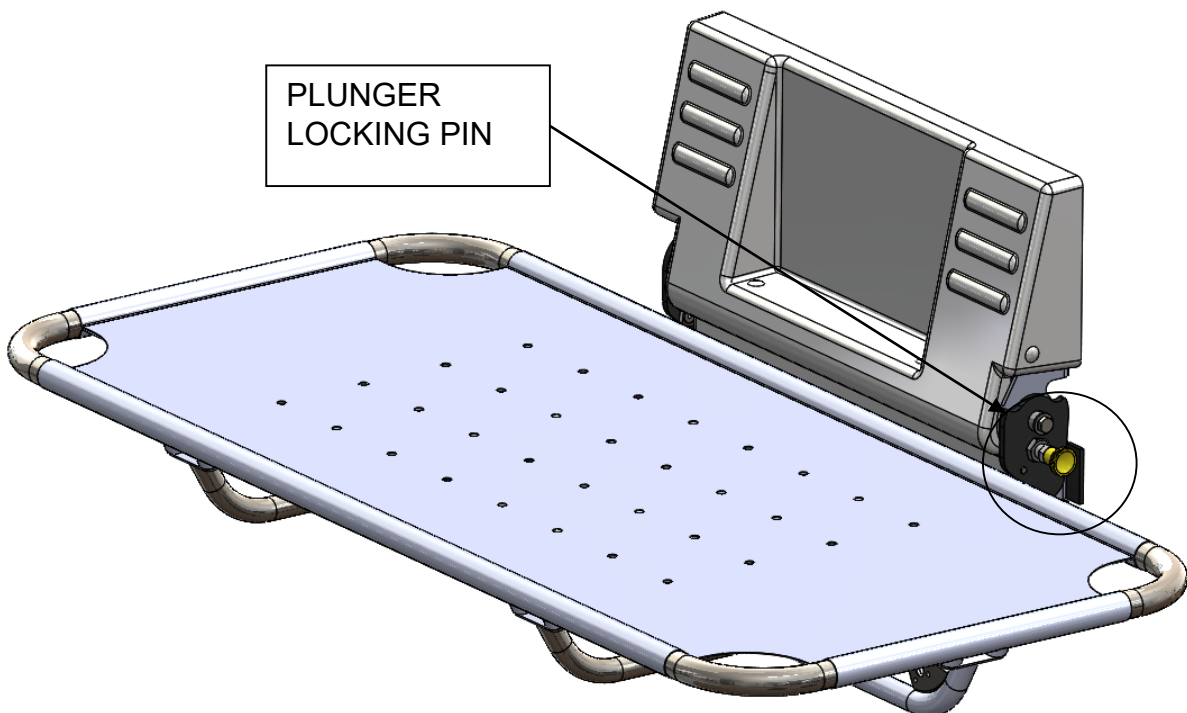

- To complete installation, it is necessary to fit the wall bracket cover to the wall bracket assembly.
- Offer up the cover to the wall bracket assembly and secure in place with 4 push fixings (D) as shown below;

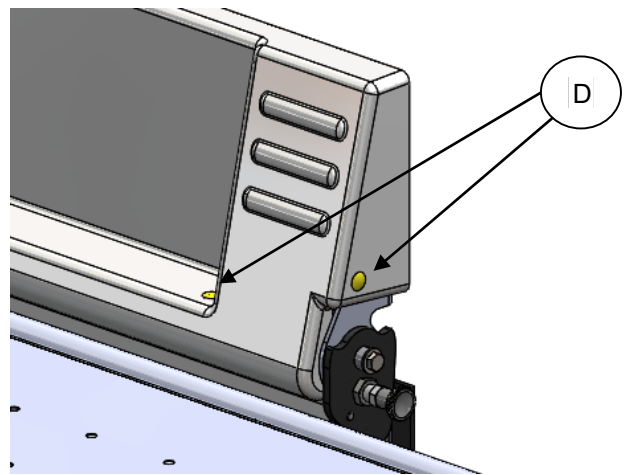
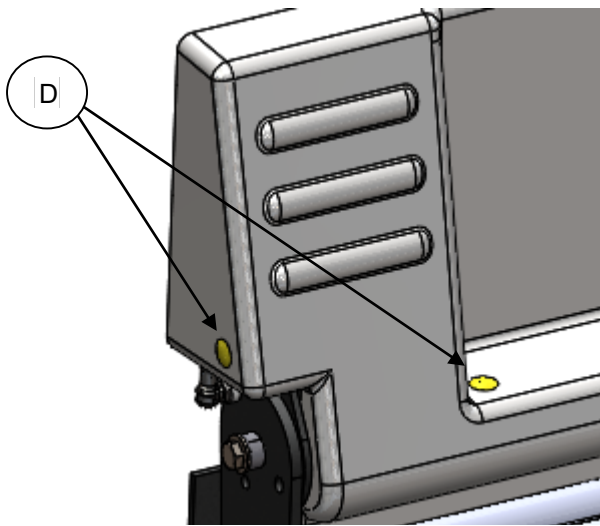

3.4 Adjustments



For non-hoist transfers always ensure the safety side is in the fully stowed position (down). When the user has been transferred onto the Easi Shower Fixed table, please ensure safety side is in the fully upright position.

3.4.1 General Use

- Where space is at a premium, the stretcher should always be stored vertically when not in use.
- By rotating the stretcher vertically, it will automatically lock into the stored position.
- To return the stretcher to horizontal for use, pull plunger pin (E), and rotate the bed to horizontal.

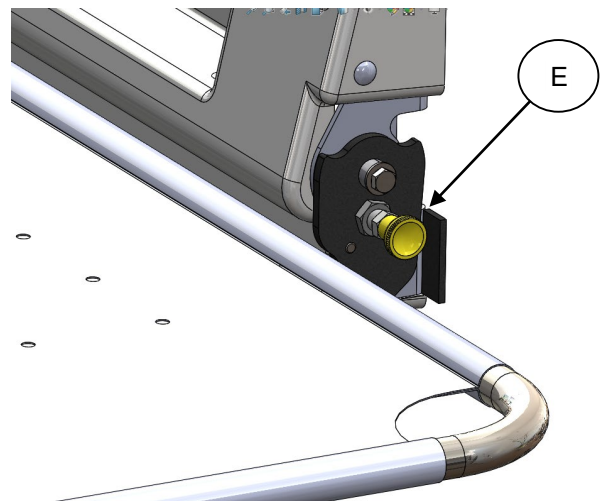

3.4.2 Head Rest

- To operate the head rest, simply pull the head rest lever (F) toward the top of the stretcher and the gas assisted head rest will rise – let go of the lever when the head rest is at the desired angle.
- To lower, simply pull the lever and push the headrest flat.

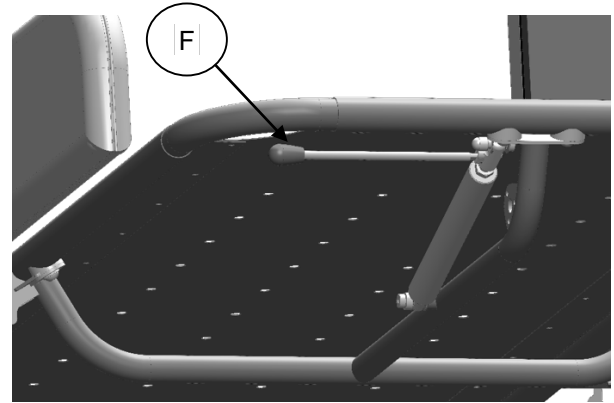

4.0 COMPATIBLE ACCESSORIES

The product comes with a variety of compatible accessories. These accessories and part codes are listed below (Table 1);

Accessory	Size 1 Code	Size 2 Code	Size 3 Code	Size 4 Code	Size 5 Code	Size 6 Code
Safety Rail	ECSG01					
Backing Board	BK093					
Drip Tray	ECST001	ECST003	ECST004	ECST005	ECST006	ECST007

4.1 Safety Rail

- To operate the guard rail rotate it upwards to vertical position.
- When in the upright position, lift the guard rail to engage the locking pins (G)
- To lower the guard rail, slightly lift the item to disengage the locking pins (G)
- Support the guard rail whilst rotating it underneath the bed, to hang freely.

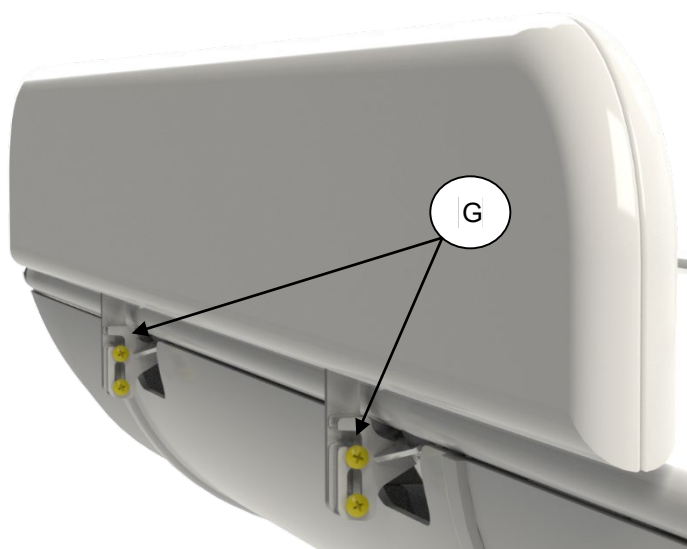

4.2 Drip Tray

4.2.1 Technical Data

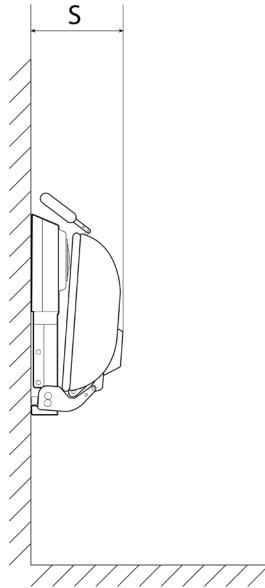

Shower Stretcher	S - Stored width with drip tray (mm)
Easi-Lift Shower Stretcher*	380
Shower Stretcher Adjustable Height*	380
Shower Stretcher Fixed Height*	340

*Please refer to the relevant IFU for full technical data for each specific shower stretcher

4.2.2 Tools Required

- A set of Hex Keys
- A set of spanners

NOTE: Help from a second person is highly recommended.

4.2.3 Parts Required

Drip Tray Frame

Quantity - 1

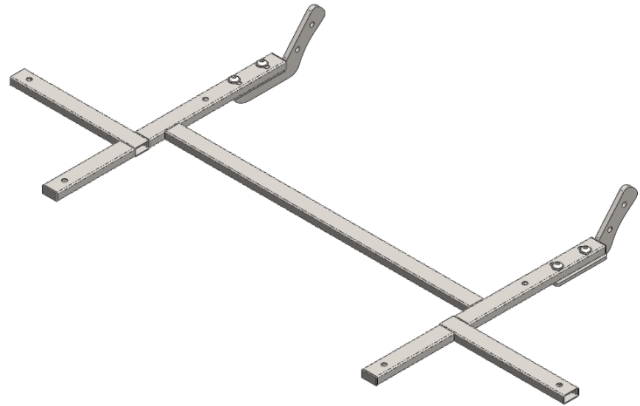

Drip Tray Frame Extension

Quantity - 2

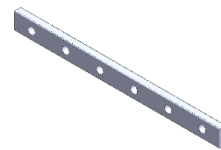

Drip Tray

Quantity - 1

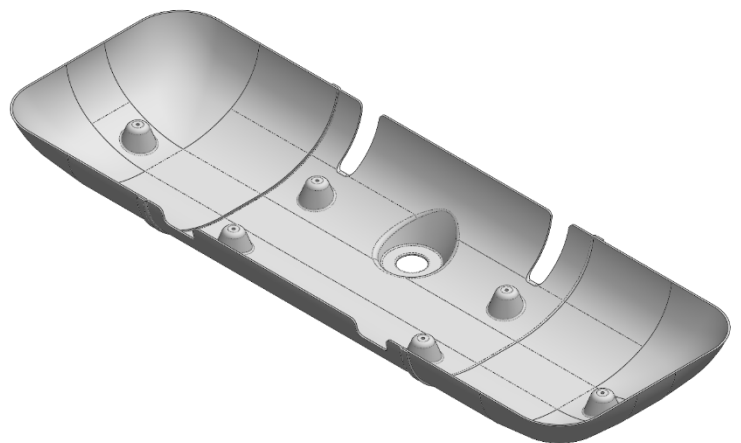

Assembly Component Kit

Quantity - 1

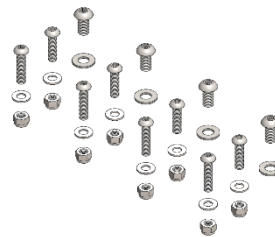

Hose

Quantity - 1



4.2.4 Installation

- Carefully unpack the shower stretcher and lay all parts on to the floor.
- Check all component packs are present.
- Check all components for damage that may have occurred during transit.

A shower stretcher should already be installed (see relevant IFU for instructions) before attaching the drip tray. The installation procedure for the drip tray is similar for all Smirthwaite shower stretcher products. For the purpose of this IFU, a Manual Adjustable Shower Stretcher has been used.

Ensure the shower stretcher is in the stowed position before starting the installation procedure (see relevant IFU for instructions).

- Loosen the 4 bolts (highlighted in Fig.1) at the back of the drip tray frame.

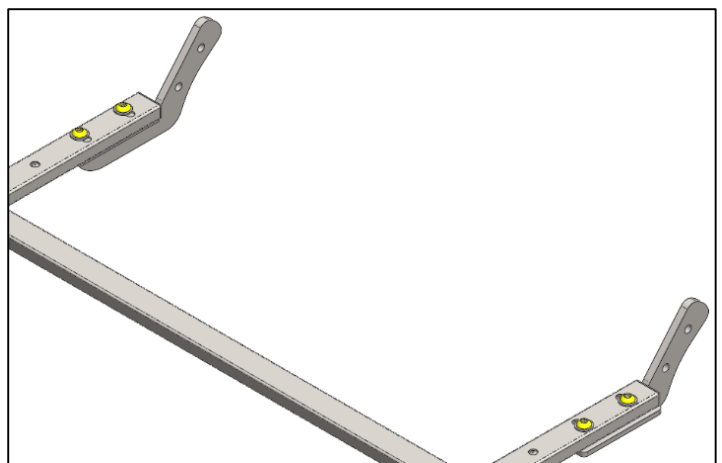

Fig. 1

- Offer the drip tray frame up to the shower stretcher and secure in place using the M10x20 bolts and washers (highlighted in Fig.2). Ensure that the profiles of the drip tray frame and the arms on the shower stretcher back frame are aligned.

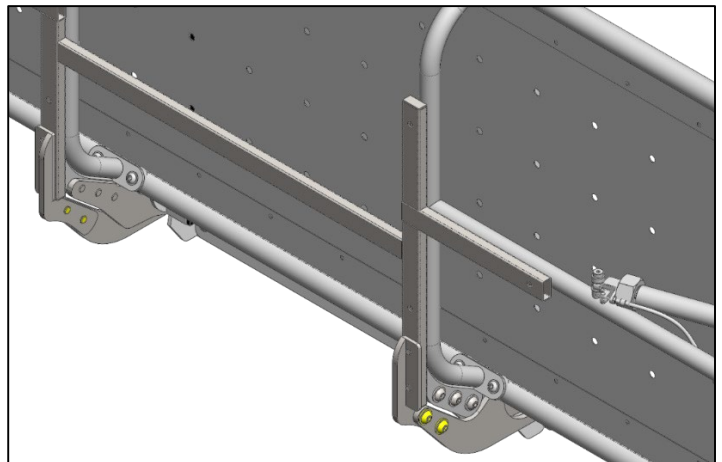

Fig. 2

COMPATIBLE ACCESSORIES

- Locate the plunger pin on the left-hand side of the shower stretcher (highlighted in Fig.3). With one hand on the drip tray frame, use your other hand to pull the head of the pin out, rotate it 90° and release it so that it stays in the unlocked position.
- Pull the drip tray frame down until it is roughly level with the floor. Then rotate the head of the plunger pin 90° and release.
- Move the frame up and down slightly until you hear the plunger pin 'click' into place.

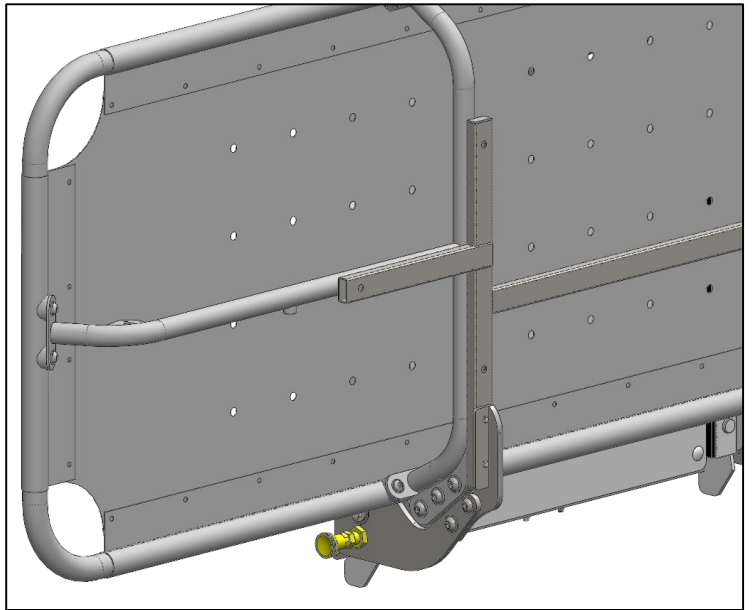

Fig. 3

- The product should look similar to the image shown in Fig.4.
- Tighten the bolts that were loosened on the frame earlier (shown in Fig.1).

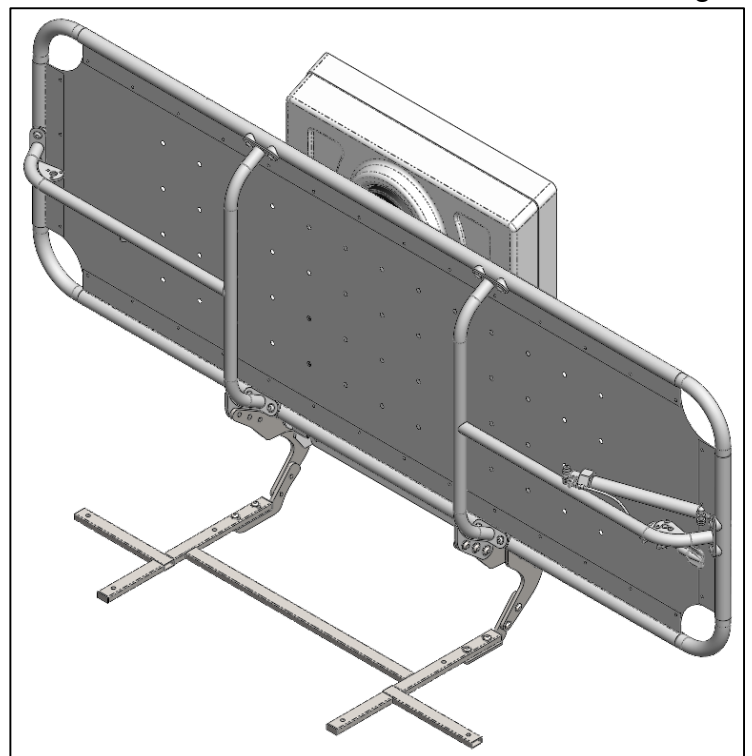

Fig. 4

- Offer up the drip tray to the underside of the frame and line up the holes. Secure in place using the M8x25 bolts, washers and nuts (highlighted in Fig.5). Ensure the drainage hole is towards the back of the shower stretcher, closer to the wall.
- Insert the tray frame extensions into the frame and align the holes with the drip tray and the drip tray frame.

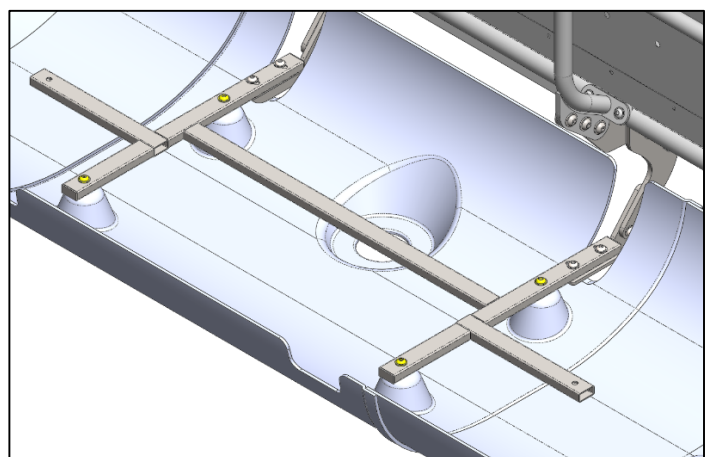

Fig. 5

COMPATIBLE ACCESSORIES

- Secure in place using the M8x20 bolts, washers and nuts. (highlighted in Figure 6).

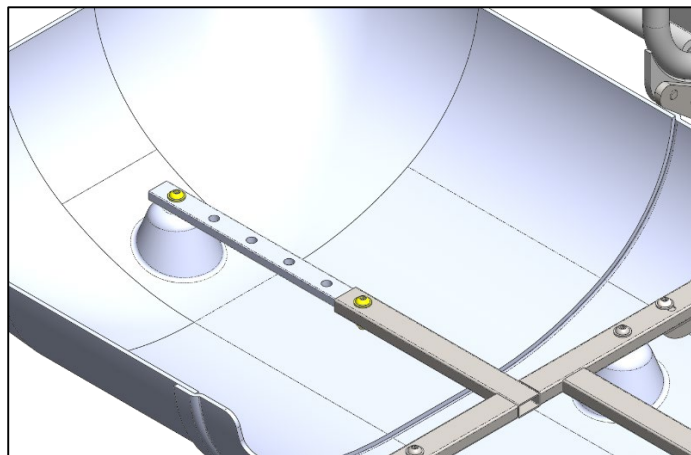

Fig. 6

- Pull out the head of the plunger pin (shown in Fig.7). With the other hand, start to raise the drip tray.

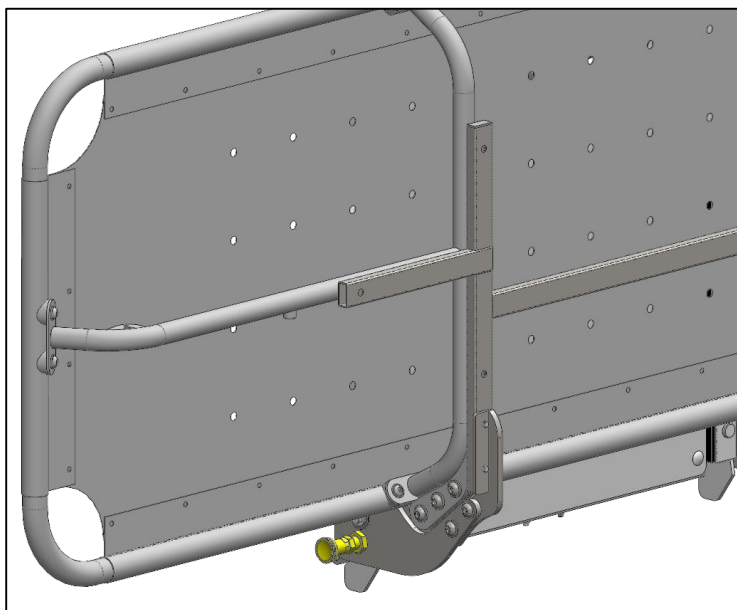

Fig. 7

- Once the tray has started to move, release the plunger pin and continue to lift the drip tray until the plunger pin 'clicks' into position. The product is now in the 'stowed' position (Fig.8).

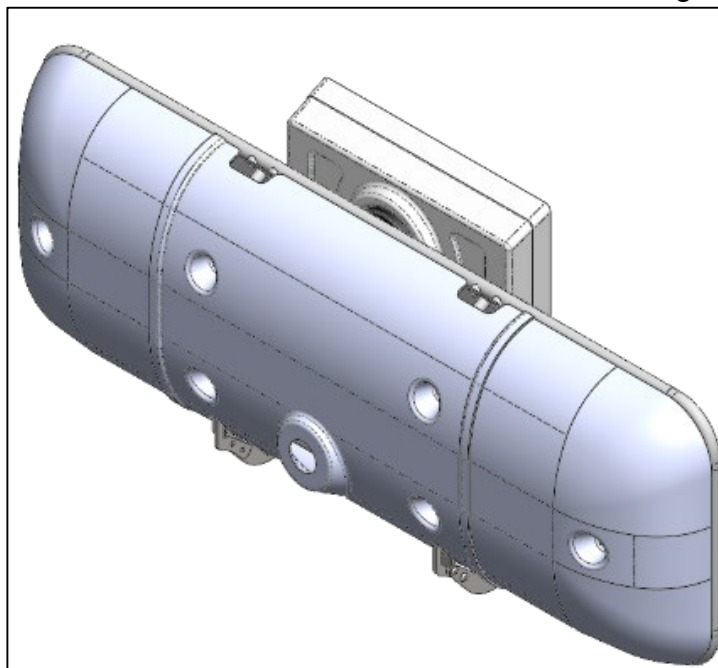

Fig. 8

4.2.5 Attaching The Hose

- To attach the hose, press it onto the connector on the bottom of the drip tray and secure in place using the threaded attachment on the end of the hose (Fig.9).

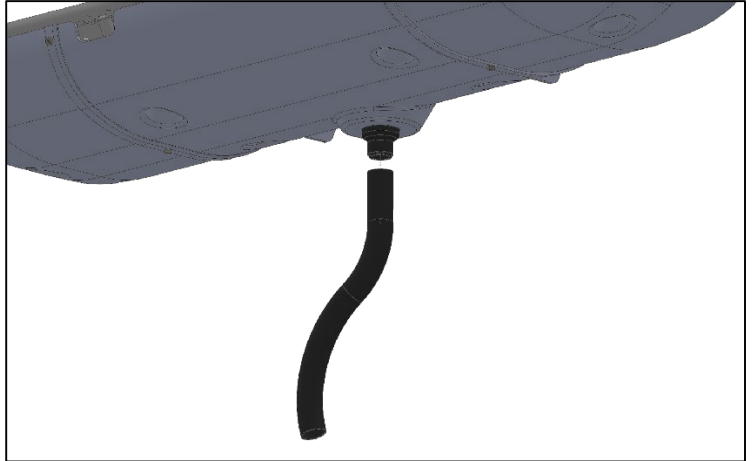

Fig. 9

4.2.6 Using The Drip Tray

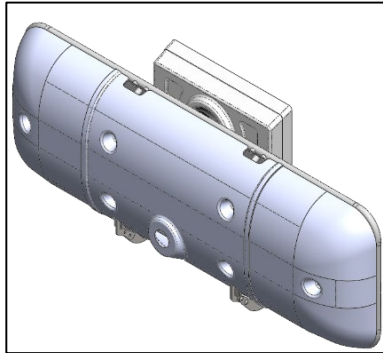

Fig. 10

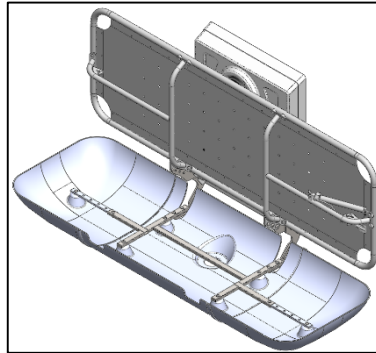

Fig. 11

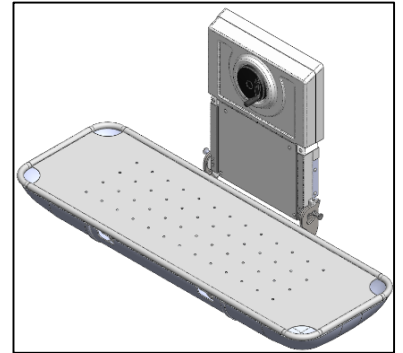

Fig. 12

4.2.6.1 Lowering The Drip Tray (Fig.10 - Fig.11)

- Locate the plunger pin on the left-hand side of the back frame (highlighted in Fig.13). With one hand on the back of the drip tray, pull the head of the plunger out and rotate it 90° so that it stays in the locked position.
- Release the plunger pin and lower the drip tray down until it is roughly horizontal.
- Rotate the head of the plunger pin 90° and move the drip tray up and down until the plunger pin 'clicks' into place.

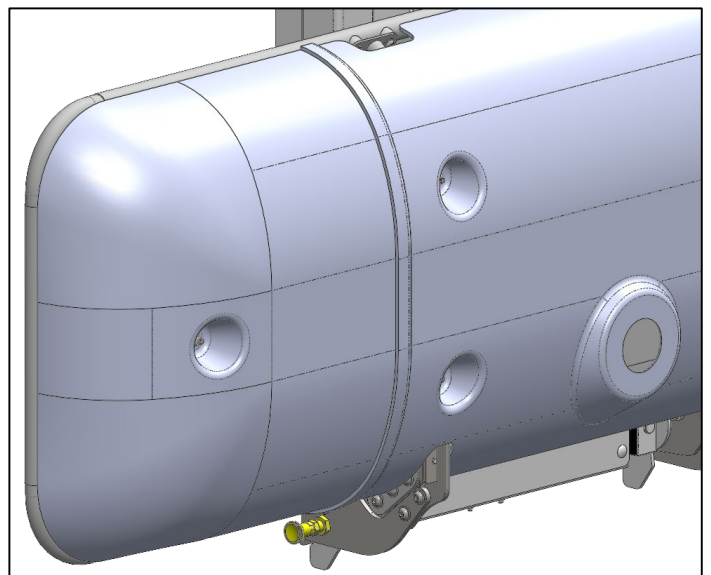

Fig. 13

4.2.6.2 Lowering The Stretcher (Fig.11-Fig.12)

- Pull the head of the plunger pin on the left-hand side of the back frame (Fig.13), rotate it 90° and release.
- Locate the plunger pin on the right-hand side of the back frame (highlighted in Fig.14).
- With one hand on the shower stretcher, pull the head of the plunger pin out and start to lower the stretcher.
- Release the plunger pin and continue to pull the stretcher down until you hear the plunger pin 'click' into place.
- Rotate the head of the left-hand plunger pin (Fig.13) 90° and move the drip tray up and down until the plunger pin 'clicks' into place.

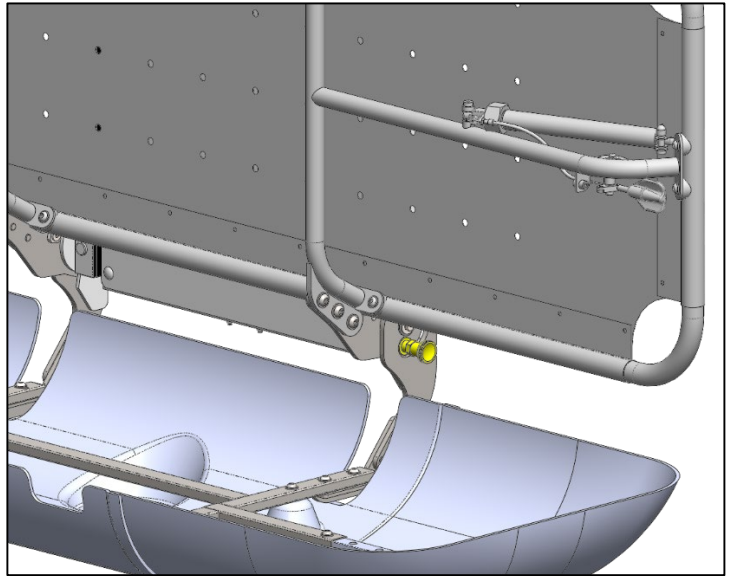

Fig. 14

4.2.6.3 Lowering The Stretcher and Drip Tray Together (Fig.10 – Fig.12)

- To move the stretcher and drip tray down together, locate the plunger pin on the right-hand side of the back frame (highlighted in Fig.14).
- With one hand on the back of the drip tray, pull the head of the plunger pin out and start to lower the shower stretcher and the drip tray down. Once the stretcher has started to move, release the pin.
- Continue to lower the stretcher and drip tray until you hear the plunger pin 'click' into place.

4.2.6.4 Raising The Shower Stretcher (Fig.12 – Fig 11)

- Pull the head of the plunger pin on the left-hand side of the back frame (Fig.13), rotate it 90° and release.
- Pull the head of the plunger pin on the right-hand side of the back frame (Fig.14) and with your other hand, start to lift the shower stretcher.
- Release the plunger pin and continue to lift the stretcher until you hear the pin 'click' into place.
- Rotate the head of the left-hand plunger pin 90° (Fig.13) and move the drip tray up and down until the plunger pin 'clicks' into place.

4.2.6.5 Raising The Drip Tray (Fig.11 – Fig.10)

- Pull the head of the plunger pin on the left-hand side of the back frame (Fig.13) and with your other hand, start to raise the drip tray.
- Release the plunger pin and continue to lift the drip tray until the pin 'clicks' back into place.

4.2.6.6 Raising The Stretcher and Drip Tray Together (Fig.12 – Fig.10)

- Pull the head of the plunger pin on the right-hand side of the back frame (Fig.14) and with your other hand, start to lift the shower stretcher.
- Release the plunger pin and continue to lift the stretcher and drip tray until you hear the pin 'click' into place.

4.2.7 Adjustments

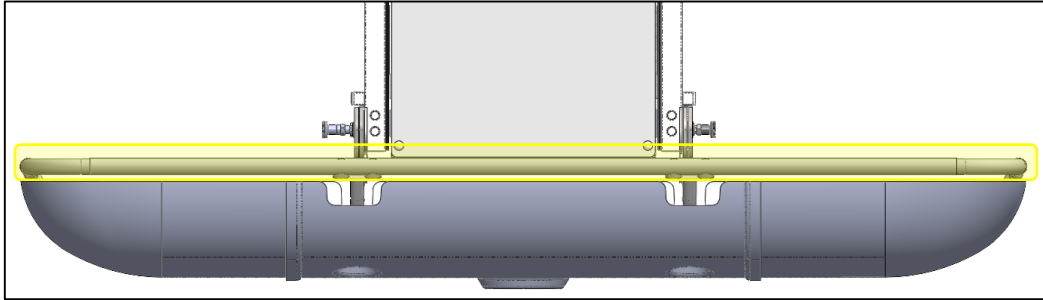

Fig. 15

- When the drip tray has been assembled and is in the position (shown in Fig.12), there should be an even, horizontal gap between the drip tray and the shower stretcher (as shown in Fig.15).
- If this is not the case, then the attachment of the drip tray needs to be checked first followed by adjustment of the tray angle stops.

4.2.7.1 Drip Tray Attachment Check

- Loosen the bolts highlighted in Fig.16
- Adjust the drip tray to the desired position and tighten the bolts to secure in position.
- NOTE: The edges of the plates in the highlighted region should be flush but this may be different on your product.

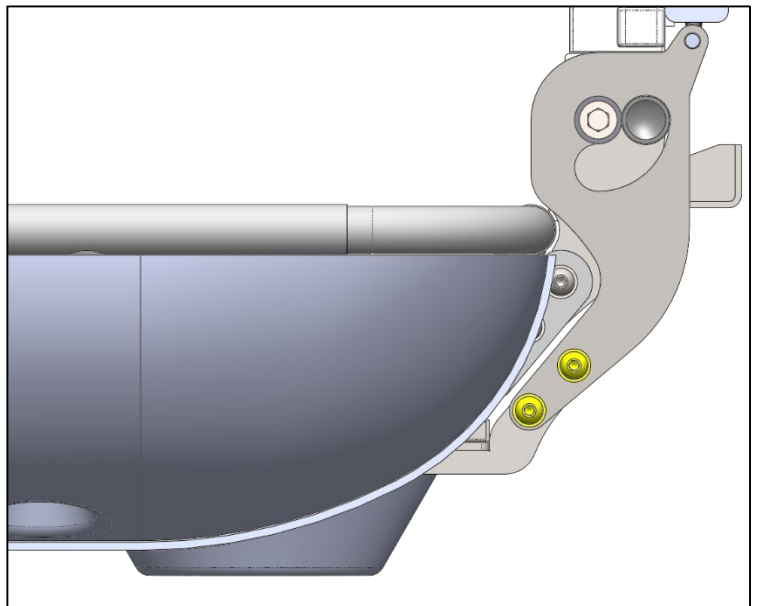

Fig. 16

4.2.7.2 Angle Stops

4.2.7.2.1 Adjustable Height Shower Stretchers

- Locate the angle adjustment screws on each side of the back frame (highlighted in Fig.15).
- Use a hex key to adjust the height of these screws which will alter the angle of the drip tray.
- Repeat for the other side.

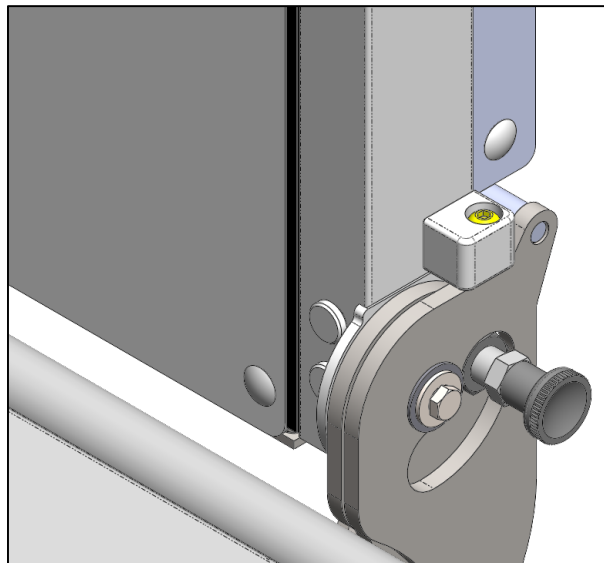

Fig. 17

4.2.7.2.2 Fixed Height Shower Stretcher

- Locate the angle adjustment bolts and locknuts on each side of the back frame (highlighted in Fig.18).
- Use a spanner to first loosen the nut. Then use a couple of spanners to set the bolt at the correct depth.
- Tighten the nut against the back plate.
- Repeat for the other side.

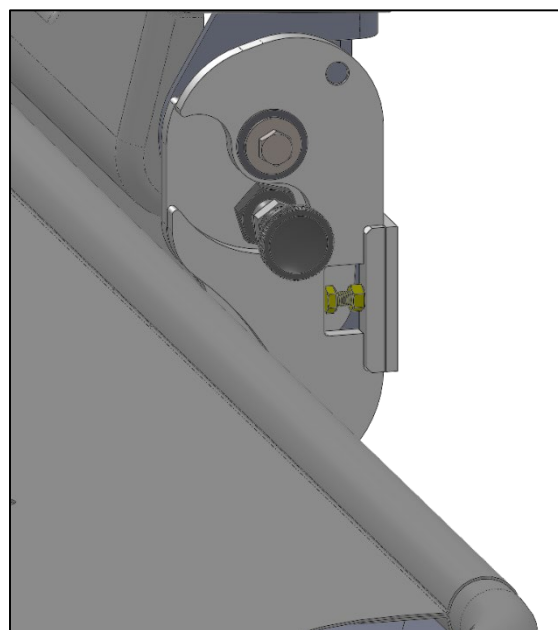
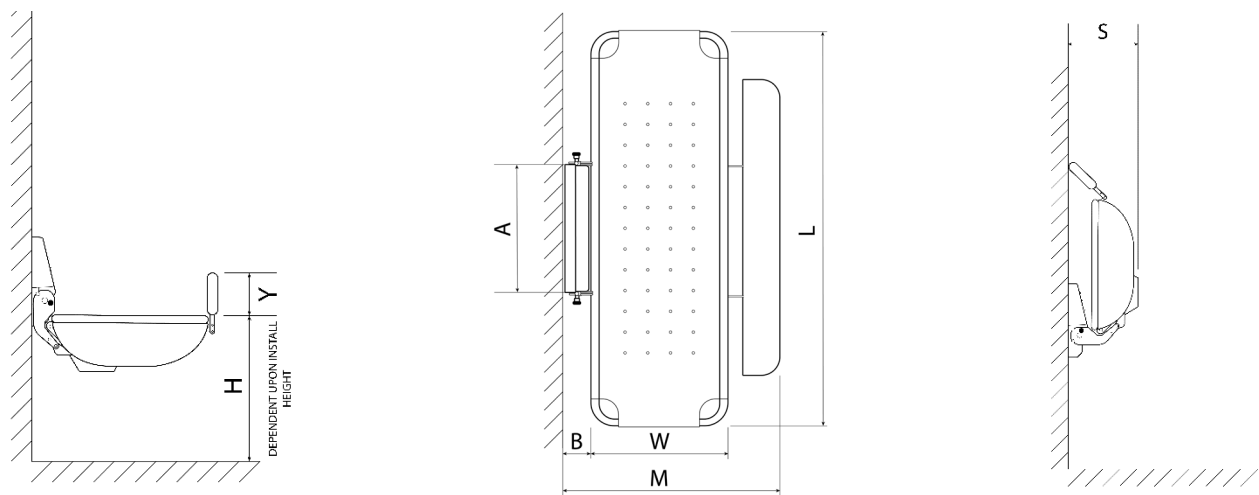

Fig. 18

5.0 TECHNICAL SPECIFICATION

5.1 Shower Stretcher Dimensions



The diagram above shows the relevant dimensional sizes of the Shower Stretcher. Below (Table 3) is a table containing the dimensions of each size. All dimensions are in mm unless otherwise specified.

Measurement		Size 1	Size 2	Size 3	Size 4	Size 5	Size 6
	Product Code (No Headrest)	3171	3172	3173	3174	3175	3176
	Product Code (Headrest)	3271	3272	3273	3274	3275	3276
	Max User Weight (kg)	200					
H	Height Range (mm)*	Fixed	Fixed	Fixed	Fixed	Fixed	Fixed
Bed Dimensions							
L	Length (mm)	1400	1500	1600	1700	1800	1900
W	Width (mm)	650					
M	Width (mm)**	1000					
Safety Sides							
Y	Height (mm)**	145					
Wall Frame							
A	Width (mm)	665					
B	Depth (mm)	80					
Storage							
S	Width (mm)	240					
S	Width with Drip Tray (mm)	340					
	Product Weight (kg)	75	76	77	78	79	80

Table 3

*Dependant on install height
 **When fitted with stowaway safety rails

5.2 Environmental - Storage and Operating Conditions

The Shower Stretcher is intended for internal use within normal environmental conditions.

It is not intended to be used in environments where there are rapid changes in the environmental temperature and humidity during intended use.

The Easi Shower Fixed suffers little from any effects of lint, dust and light.

- Lint – Due to there being no mechanical or electrical mechanisms on the Easi Shower Fixed, lint would not affect the Shower Stretcher working.
- Dust – Due to there being no mechanical or electrical mechanisms on the Easi Shower Fixed, dust would not affect the Shower Stretcher working.
- Light – The Specification of the Shower Stretcher dictates that normal use would occur during ambient luminance 50 – 500 lux. Additionally, as the Shower Stretcher is designed for indoor use only, if required the user may wish to switch on room lighting.

5.2.1 Normal operating conditions

+5°C to +40°C (41°F to 104°F) at a relative humidity between 15% to 90% RH, non-condensing but not requiring a water vapour pressure greater than 50hPa and atmospheric pressure between 700hPa to 1060hPa

5.2.2 Shipping and storage conditions

-25°C to +5°C (-13°F to 41°F) with any humidity level

+5°C to +35°C (41°F to 95°F) at a relative humidity up to 90%,

+35°C to 70°C non-condensing at a water vapour pressure up to 50hPa

During all transportation it is recommended that the Shower Stretcher remains in its original packaging.

It is recommended that the Shower Stretcher is stored in a cool, dry place out of direct sunlight. If cleaning is required after storage, please see section 7.0 Cleaning of the user manual for instructions.

Shipping and storage conditions are also contained on Easi Shower Fixed Box Label:

SN	<input style="width: 90%;" type="text"/>		<input style="width: 90%;" type="text"/>	 <small>smirthwaite</small> <small>europa healthcare company</small>
REF	<input style="width: 90%;" type="text"/>		MD - Medical Device	
Product:		<input style="width: 100%; height: 100%;" type="text"/>		SWL : <input style="width: 80%;" type="text"/>
				Built By: <input style="width: 80%;" type="text"/>
 Smirthwaite Ltd, Heathfield, Newton Abbot TQ12 6TL				
EC REP	European Healthcare & Device Solutions (Ireland) Ltd, Stratton House, Bishopstown Road, Cork, Ireland.			
Manufactured in the UK Removal of this label will invalidate the warranty				

5.3 Standards Applied

The standards that have been applied to the device are as follows:

- BS EN ISO 12182:2012 (Assistive products for persons with disability. General requirements and test methods).
- IEC 62366:2015 (Application of usability engineering to medical devices).
- BS EN ISO 15233-1 :2016 (Medical devices — Symbols to be used with medical device).

5.4 Disposal



Please observe the local laws on recycling and respect the current laws for disposal within the community the device is being used within. If there is any uncertainty of the below guidelines, contact your local authorities to determine the proper method of disposal of potentially bio-hazardous parts and accessories.

6.0 GENERAL INSPECTION AND MAINTENANCE



No maintenance is to be carried out on the Shower Stretcher while in use to reduce the risk of injury.

The user will not require any tools when completing their inspections.

When completing services, the authorised service engineer will provide their own tools, including:

1 x set of metric Allen keys.

6.1 Daily Checks - To Be Completed by User

Prior to each use the Easi Shower Fixed must be inspected visually.



Should any of these items fail the inspection, DO NOT use the Shower Stretcher. Contact your local authorized dealer for service – contact details are on the last page of this manual.

Visually check for the following:

- Check the mattress for signs of damage or wear and tear
- Keep the upholstery and metal parts clean
- Check the safety rail can be stowed and locked into the vertical position
- Check that the bed rises and lowers when activated by the handset
- Check that the bed can be securely stored in the vertical position, and that the plunger locking pin engages.

6.2 Service Interval

The Easi Shower Fixed should be serviced every 1 year. Servicing must only be undertaken by a Smirthwaite Ltd. service engineer, or by a Smirthwaite Ltd. trained representative.

6.3 Nominal Service Life

Your product has a nominal service life of 7 years, during which full post-sales support will be available with regard to spares and servicing.

Product service life has been determined based upon the design complexity of product, and the anticipated exposure to normal use.

Good practice dictates all Smirthwaite Ltd. products have been designed and manufactured to high levels of safety and quality, and will meet requirements of normal use when maintained in line with our servicing recommendations.

GENERAL INSPECTION AND MAINTENANCE



If the product has been out of use for an extended period of time (6 months or more) it should always be serviced prior to being reissued. If the product has been subjected to 'heavy' or 'constant' use, the service should be reduced to half the recommended period.

Constant and/or heavy use is considered to be:

- Daily use above 7 hours' duration.
- Weekly use above 5 days' duration.
- Monthly use above 10 months per year.
- Use by a client who is at 90% to 100% of the maximum weight limit of the product. The maximum weight limit must NEVER be exceeded.
- Use by a client who is extremely active, either voluntarily or involuntarily.

6.4 Extending Nominal Service Life

At Smirthwaite Ltd. we are proud to produce products that have a reputation for quality and durability.

We believe our products have the potential to provide benefits to our clients beyond the nominal service life documented above.

We will continue to provide full support beyond the nominal service life provided the following conditions are met:

1. A full service schedule has been maintained.
2. A full service and inspection is undertaken at the end of the nominal service life period.
3. The product is subsequently serviced annually (or biannually if under 'heavy/constant' use conditions).
4. Smirthwaite Ltd. reserve the right to limit support where parts/components are no longer available.

6.5 User Serviceable Parts

Please contact Smirthwaite Ltd. or your local dealer for information to assist service requirements on the Easi Shower Fixed – e.g. to ascertain the necessary information for replacement parts and components. Contact details are shown on the last page of this manual

6.6 Final Inspection

When the service is complete:

- Remove any waste created as part of the service from the site.
- Confirm with the operator if the Shower Stretcher is safe to use and that it has been left in a working state. Isolate the Shower Stretcher if it is not safe to operate.
- Complete all documentation – see section '8.0 Service Documentation.'



Incorrect use may result in personal injury or damage to objects

7.0 CLEANING

Please follow the cleaning guidelines below; noting the frequency is appropriate with usage.



It is recommended to clean the Easi Shower Fixed and accessories before use by a different person, reducing the risk of cross-contamination.

7.1 General cleaning

The exterior of the Easi Shower Fixed can be cleaned using a damp soapy cloth for general cleaning duties. Please ensure the cloth is damp and not wet. Ensure the exterior of the Shower Stretcher is dry after cleaning. Dry using a clean dry cloth.

- Upholstery - damp cloth and mild detergent.
- Wooden Parts - damp cloth and mild detergent.

Key cleaning points include;

- Stubborn marks on the woodwork should be cleaned by using a soft brush.
- Do not soak or immerse the Shower Stretcher in water.
- The pelvic strap can be cleaned with a damp cloth. In cases of extreme soiling it can be machined washed at low temperature with mild detergent but must be drip dried.
- Store the Shower Stretcher in a cool dry place out of direct sunlight.



DO NOT use bleach, solvents, abrasives, synthetic detergents, wax polishes, antibacterial sprays or wipes.

For further information, please refer to MHRA or your NHS cleaning guidelines.

8.0 SERVICE DOCUMENTATION

8.1 Documentation/ Records

It is the responsibility of the current equipment owner to ensure the Service Manual (As well as any further manuals for accessories fitted to the equipment) are handed over to the new owner at the time of exchange/sale.

It is the responsibility of the current equipment owner to ensure the service and inspection record form is kept up to date.

8.2 Service Record History

Complete this record after each service, repair inspection and/or maintenance.

* Photocopy additional pages as required *

8.2.1 Product Information

Model	
Size	
Date of Manufacture	
Serial Number	

8.2.2 Service & inspection record form:

Date	Procedure	Service Personnel

9.0 WARRANTY

Smirthwaite Ltd warrants the products detailed on your order to be free from defects in materials and workmanship for a period of 2 years from date of delivery. If a fault develops during the period, please call Customer Services by email or telephone 01626 835552 who will advise you on the best course of action. Possible action may be for us to arrange to send out one of our Service Engineers, or have the goods returned to us. Should a repair not be possible within the guarantee period we will replace the product for new or nearest equivalent product. In the unlikely event that we cannot repair or exchange we will refund in full.

This warranty is in addition to your legal rights. Goods will only be collected from the original delivery address.

A charge may be made where the goods cannot be repaired under the terms of the warranty. You will be advised before this is made.

T: +44 (0)1626 835552

E: info@smirthwaite.co.uk

10.0 CONTINUOUS IMPROVEMENT

Smirthwaite Ltd are committed to continuous improvement to their product range. Should you have any suggestions or comments please send them to our product design department at:

info@smirthwaite.co.uk

Smirthwaite Ltd reserve the right to change the specification or material without prior notice.

For catalogues, help and further information on our products please contact us at:

Smirthwaite Ltd 16 Wentworth Road Heathfield, Devon.TQ12 6TL

T: +44 (0)1626 835552

E: info@smirthwaite.co.uk

W: www.smirthwaite.co.uk



Smirthwaite Ltd, 16 Wentworth Road • Heathfield • Newton Abbot • Devon • TQ12 6TL

Part Number: 999-1-15 / Rev: 2 / Date: Sep 21